

NAME _____
SCHOOL _____

INDEX NO. _____
SIGNATURE _____
DATE _____

232/1
PHYSICS
PAPER 1
JUNE, 2025
TIME: 2 HOURS

EMUHAYA CLUSTER EXAMINATIONS TERM 2 2025

232/1
PHYSICS
PAPER 1
(THEORY)
TIME: 2 HOURS

INSTRUCTIONS TO CANDIDATES

- Write your name, school and index number in the spaces provided above.
- Write the date of examination and sign in the spaces provided above.
- This paper consists of two sections, Section **A** and **B**.
- Answer **ALL** the questions in section **A** and **B** in the spaces provided.
- **ALL** answers and working **MUST** be clearly shown.
- Mathematical tables and electronic calculators **may be** used.
- Take acceleration due to gravity, $g = 10\text{m/s}^2$

FOR EXAMINER'S USE ONLY:

Section	Question	Maximum score	Candidate's score
A	1–12	25	
B	13	12	
	14	11	
	15	10	
	16	12	
	17	10	
	TOTAL	80	

This paper consists of 10 printed pages

Candidates should check to ensure that all pages are printed as indicated and no questions are missing

1. Figure 1 below shows a micrometer screw gauge being used to measure the diameter of a metal rod. The thimble scale has 50 divisions.

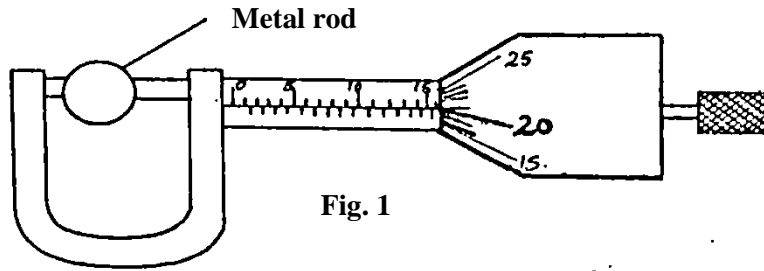

Find the diameter of the metal rod.

(1 mark)

2. A man of mass 72kg jumps from a small boat on to the lake shore with a forward velocity of 9.0ms^{-1} . If the mass of the boat is 216kg, calculate the initial backward velocity of the boat. (3 marks)

3. Explain briefly how the temperature in a green house is kept higher than outside. (2 marks)

The diagram shown in figure 2 below is an arrangement of three pulley wheels used to help in lifting loads. Use it to answer questions 4 and 5.

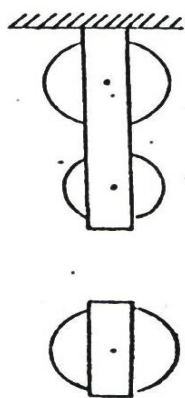

Fig. 2

4. Complete the diagram to show how the rope goes round the wheels, position of the load and the effort.

(2 marks)

5. Write down the velocity ratio (VR) of the system. (1 mark)

6. State how temperature affects the speed of sound in air. (1 mark)

7. State **two** facts which show that heat from the sun does not reach the earth surface by convection. (2 marks)

8. The diagram in figure 3 below shows water with negligible viscosity flowing steadily in a tube of different cross-section area. If at a point A, the cross section area is 120cm^2 and the velocity of water is 0.40ms^{-1} , calculate the velocity at B where cross section area is 4.0cm^2 ? (3 marks)

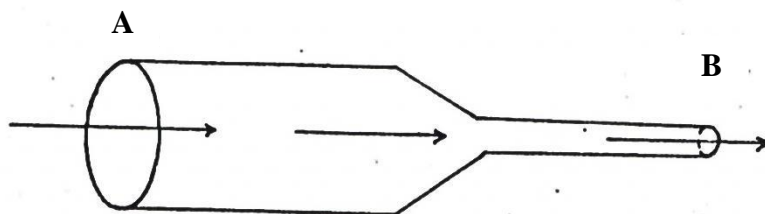
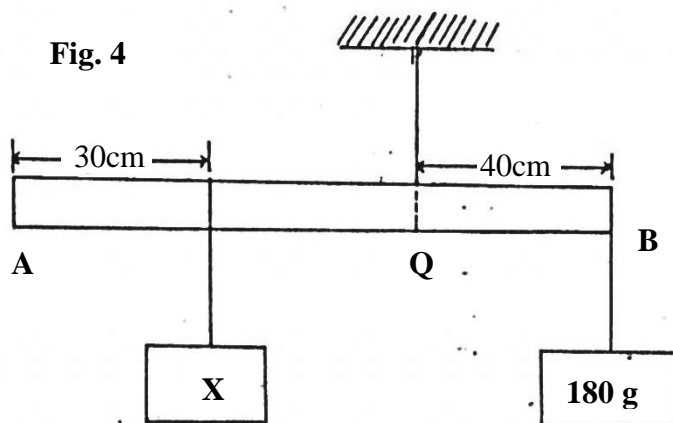

Fig. 3

9. A motor uses an electrical energy at a rate of 200W and raises a mass of 25kg through a vertical distance of 20m in 0.5 minutes. Determine the efficiency of the motor. (3 marks)

10. How long will it take 240V, 3000W electric immersion heater to raise the temperature of 150 litres of water in a well-lagged calorimeter made of copper of mass 20kg from 15⁰ to 70⁰C? (3 marks)

11. The diagram shown in the Figure 4 below shows a system in equilibrium with the rule horizontal. AB is a uniform rule of length 1.0m and weight 1.8N. Calculate the weight of the block X. (3 marks)



12. State the reason why a trailer carrying heavy loads has many wheels. (1 mark)

SECTION B (55 MARKS)

Answer ALL the questions

13. A student in Lugulu Girls set up an experiment to study the acceleration of a trolley using ticker tape timer. The timer made 50 dots per second on the tape. Dots A to E measured 2.5cm apart and dots E to I measured 4.5cm apart.
- a) Using a scale drawing show the dots A, B C, D, E, F, G and I as they appeared on the tape. (3 marks)
- b) Determine the velocity of the trolley from:
- i) A to E. (2 marks)
- ii) E to I. (2 marks)
- c) Calculate the acceleration of the trolley. (2 marks)
- d) What end of the tape was fixed onto the trolley? (1 mark)
-
- e) State **two** precautions that the student should take before she takes her final samples of the dots. (2 marks)
-
-
-

- ii) A particle A of mass M moving with an initial velocity, u , makes a head-on collision with another particle B of mass $2M$, B being initially at rest. In terms of u , calculate the final velocity of A if the collision is perfectly inelastic. (3 marks)

- b) The diagram in Figure 5 below shows a sphere moving in a viscous liquid in a tall measuring cylinder.

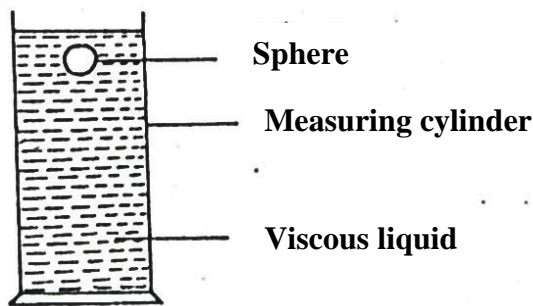

- i) Show on the diagram the forces acting on the sphere. (3 marks)
- ii) Sketch a graph showing the variation of velocity with time in figure 6 below. Show on the graph the terminal velocity, V_T . (2 marks)

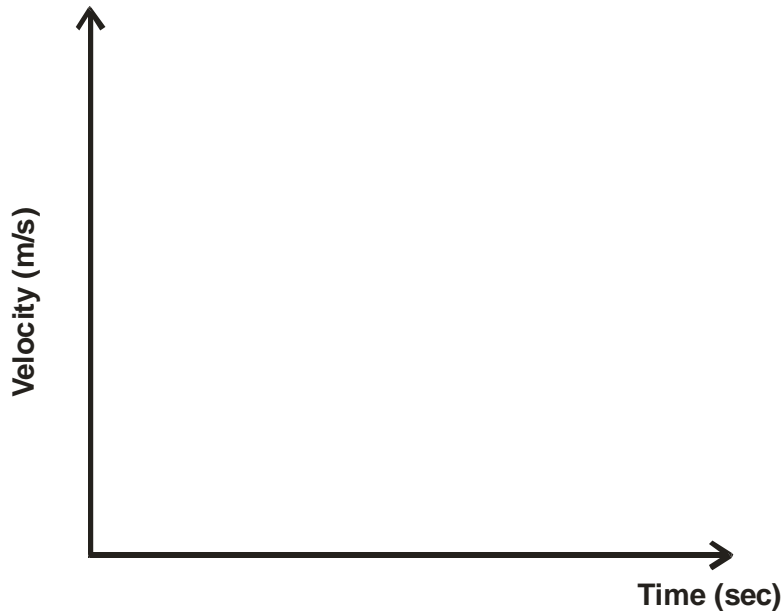

16. A mass of 1kg is attached to a cord of length 50cm. It is whirled in a circle in a vertical plane at 10 revolutions per second as shown in the figure below.

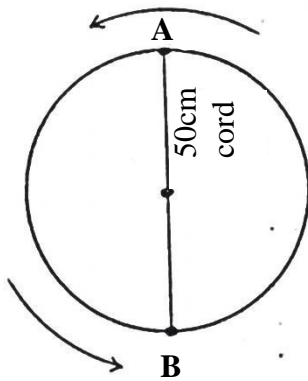

a) Find the tensions in the cord when the mass is at:

i) Highest point of the circle A. (2 marks)

ii) Lowest point of the circle B. (2 marks)

b) i) Describe an experiment to determine specific heat capacity of aluminium block with two holes drilled in it to accommodate a thermometer and an electric heater. (5 marks)

- ii) An immersion heater rated 90W is placed in a liquid of mass 2kg. When the heater is switched on for 15minutes, the temperature of the liquid rises from 20°C to 30°C. Determine the specific heat capacity of the liquid. (3 marks)

17. a) The figure below shows a block of mass 25g and density 200kg/m³ submerged in a certain liquid and suspended from a homogenous horizontal beam by means of a thread. A mass of 2kg is suspended from the beam as shown in the figure below.

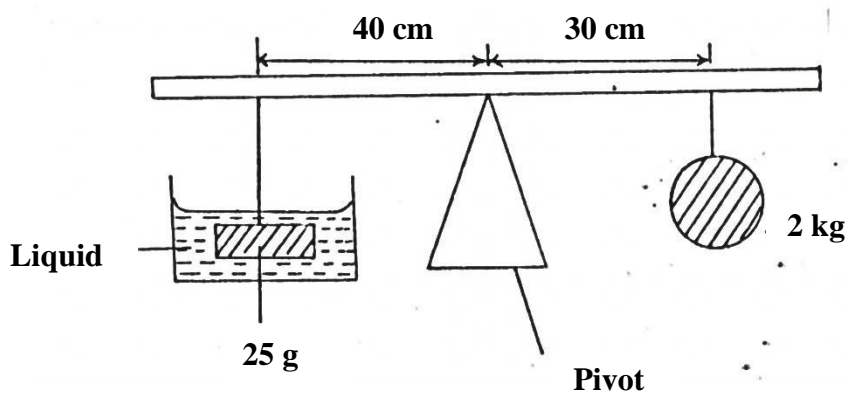

- i) Determine the upthrust force acting on the block. (3 marks)

- ii) Calculate the density of the liquid. (3 marks)

b) i) State the law of floatation.

(1 mark)

ii) The figure below shows a piece of aluminium suspended from a string and completely immersed in a container of water. The mass of the aluminium is 1kg and its density is $2.7 \times 10^3 \text{kg/m}^3$

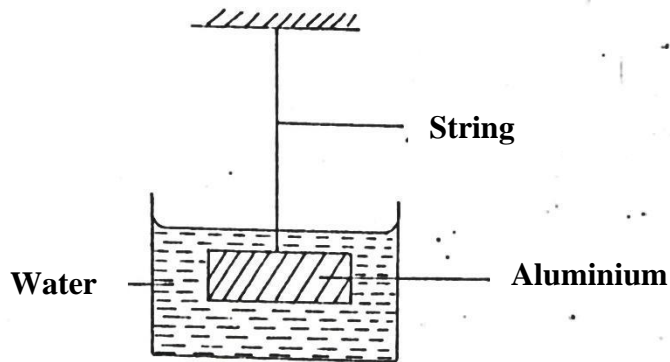

Calculate the tension in the string.

(3 marks)